

Project summary

**EWG Pankow
Berlin
Germany**



Description

In 2006 the EWG Berlin-Pankow, a building association located in north-east Berlin, started comprehensive modernisation and reconstruction measures on seven multi-family buildings of one building type. By centralisation of heating and hot water generation the most important condition for solar thermal were created. In five of the buildings also other boundary conditions (direction of the roofs) fit well for the integration of a solar thermal plant.

Task for the planner was to create a system that realises solar thermal by reasonable costs and light constructional changes on the buildings. It was also predetermined, that the compact heating stations should not be changed due to solar thermal installation. Under these circumstances it has been decided to build a direct-feed-in system.

Building

Type of building	Multi-family house
Number of users / dwellings, floors	300 users 148 dwellings 4 floors
Year of construction	1959
Total effective area (heated)	7,634 m ²
Hot tap water consumption (calculated)	n. a. m ³ /a,
Whole energy consumption for heating purpose after CSTS implementation	852,000 kWh/a

System engineering

Year of construction of CSTS	2006
Type of collectors	Flat plate collectors
Thermal power	100 kW _{therm}
Aperture area of collectors ^{*)}	146 m ²
Buffer storage	./. m ³
Hot tap water storage	1.7 m ³
Total capacity of boilers (natural gas)	140 kW
Type of hot tap water heating	Centralised
Type of heating system	Centralised

Costs

Total cost solar system	106.400 Euro
Cost of CSTS / gross area of collectors	626 Euro/m ²
Subsidies	0 %

Output

Output of solar heat ^{**)}	73.100 kWh/a
Reduction of final energy ^{***)}	59,900 kWh/a
CO ₂ -emissions avoided	15.4 t CO ₂ /a
Solar performance guarantee	No

^{*)} Aperture area = light transmitting area of the front glass

^{**)} measured, between storage and piping to taps (solar system output)

^{***)} related to the measured output mentioned before

Owner

Erste Wohnungsgenossenschaft Berlin - Pankow e. G.
Mr. Mackenrodt / technical manager
Arconastr. 45-49
13189 Berlin, Germany
Phone: +49 30 477006-0
Fax: +49 30 477006-11
mackenrodt@ewg-pankow.de
www.ewg-pankow.de

Operator

See owner

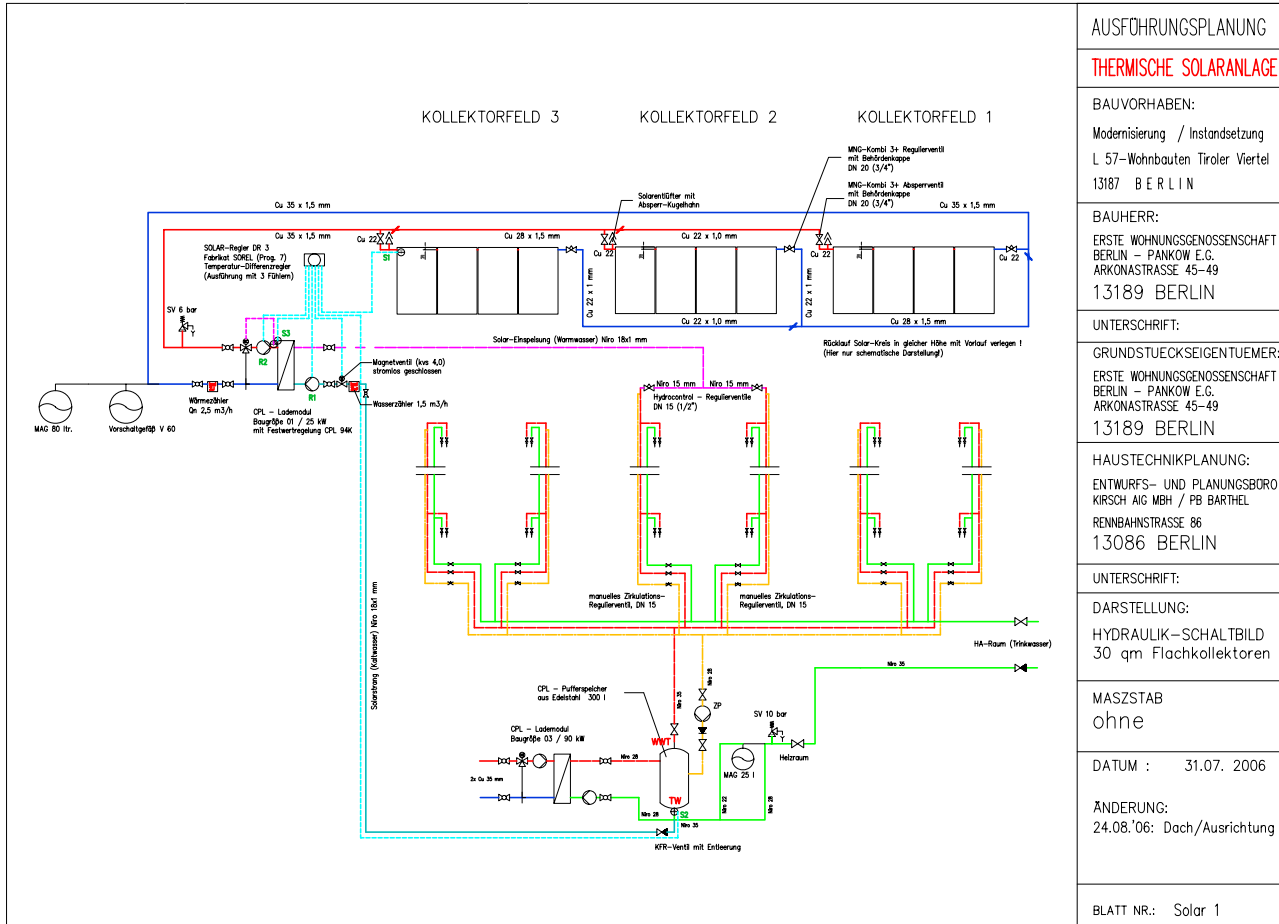

AUSFÜHRUNGSPLANUNG
THERMISCHE SOLARANLAGE
BAUVORHABEN: Modernisierung / Instandsetzung L 57-Wohnbauten Tiroler Viertel 13187 BERLIN
BAUHERR: ERSTE WOHNUNGSGENOSSENSCHAFT BERLIN – PANKOW E.G. ARKONASTRASSE 45–49 13189 BERLIN
UNTERSCHRIFT:
GRUNDSTUECKSEIGENTUEMER: ERSTE WOHNUNGSGENOSSENSCHAFT BERLIN – PANKOW E.G. ARKONASTRASSE 45–49 13189 BERLIN
HAUSTECHNIKPLANUNG: ENTWURFS- UND PLANUNGSBORO KIRSCH AIG MBH / PB BARTHEL RENNBAHNSTRASSE 86 13086 BERLIN
UNTERSCHRIFT:
DARSTELLUNG: HYDRAULIK-SCHALTBILD 30 qm Flachkollektoren
MASZSTAB ohne
DATUM : 31.07. 2006
ÄNDERUNG: 24.08.'06: Dach/Ausrichtung
BLATT NR.: Solar 1

Description of the CSTS

Year of construction of CSTS	2006
Thermal power	100 kW _{therm.}
Gross area of collectors	170 m ²
Aperture area of collectors	146 m ²
Type of collectors	Flat plate collectors
Type of assembly	Roof top
Orientation of collectors	South (0°)
Inclination angle to horizon	37°
Freezing protection	Glycol
Overheating protection	Expansion vessel
Operation mode	Variable
Use of CSTS for	Hot tap water heating
Buffer storage	no buffer storage, direct feed-in
Hot tap water storage	1,7 m ³ : 5 storage tanks: 4 × 300l, 1 × 500l
Control of backup-system / CSTS	Separated control

Hot tap water system

Type of hot water heating	Centralised
Recirculation system	Yes
For decentralised systems:	./.
The installation on the consumer site	
Size of storage for hot tap water	1.7 m ³
Specification	./.

Space heating system

Type of heating system	Centralised
Number of boilers	2
Total capacity (power output) of boilers	140 kW
Capacity of each boiler and the year of construction	No. 1: 70 kW (2006) No. 2: 70 kW (2006)
Energy source	Natural gas
Type of boiler system	Condensing

Type of operation

Operator of the CSTS system	Self-operation
CSTS monitoring	No
Data accessible via internet	No
Scientific monitoring / follow up	Yes
Maintenance contract	Yes: twice a year
Visualisation of the solar heat output	No

Yield of CSTS plant

Output of solar heat	73,100 kWh/a
Origin of data	prognosis
Measuring point	between collector and storage
Reduction of final energy	59,900 kWh/a
Origin of data	prognosis
Solar performance guarantee	No

Heat consumption

Whole energy consumption for heating purposes <i>after</i> CSTS implementation	852,000 kWh/a
Origin of data	estimated
Energy used for	Hot tap water heating, space heating
Whole energy consumption for heating purposes <i>before</i> CSTS implementation	not to determine (single flat heating and hot water generation)
Total tap water consumption	3,400 m ³ /a
Hot tap water consumption	n. a. m ³ /a,
Hot tap water temperature	60 °C
Cold water temperature	10 °C

Summary

Collectors with each 10 m² area have been mounted on the roof top. The pipes of the solar circle lead to a heat exchanger located in a garret. The secondary side of the exchanger (a new installed pipe from cellar to roof) is used as a second load circle starting before cold water entry of the hot water storage and feeding in two legs of the circulation system, that were extended to the top floor.

Solar regulation and load regulation for the hot water storage (heat up by the condensing boiler) work separated but balanced in the operational parameters.

Planning/Engineering

Planungsbüro Barthel
Mr. Barthel
Rennbahnstr. 86
13086 Berlin, Germany
Phone: +49 30 479905-0
Fax: +49 30 479905-19
PBBarthel@t-online.de



Collector field

Introduction

Definite evaluation will be possible after an operational phase of at least one year (also regarding climate influences). A second important factor for the economic valuation is the further development of energy prices. In general, the investor appreciates the installation of solar thermal as an investment in the future.

Financing of CSTS

Form of financing	Purchase
Distribution in percentage	0 %

Costs of solar materials

Total cost of solar system	106,400 Euro
Detailed costs for	
Collectors	n. a. Euro
Elevation / mounting structure	n. a. Euro
Storage / heat exchanger	n. a. Euro
Backup heater	n. a. Euro
Control	n. a. Euro
Installation	n. a. Euro
Planning / Engineering	15,000 Euro
Others:	n. a. Euro

Operation costs of heating system

Power cost for pumping	n. a. Euro/a
Maintenance cost	n. a. Euro/a
Monitoring cost	n. a. Euro/a
Other operation cost	n. a. Euro/a
Total operation cost	n. a. Euro/a
Or: Increase of operation cost after CSTS implementation	has not yet been observed



Qualitative aspects

At the beginning there has been the plan to realise a plant referring to the "Schweizer Modell" (Swiss model). That was not possible due to delivery problems with the compact module of Circo Solar. Therefore another type of direct feed-in system has been developed and implemented.

Experiences management

Experience problems or failures?

No: In the first two month after installation optimisations on the plants were done, an interruption of operation did not take place.

Find solutions to these problems or failures?

./.

Financial effects / project performance

Project economically efficient?

Yes

Fiscal or other financial effects?

Yes: running costs for heating have been reduced

Effects on rental fees?

Yes: costs for solar thermal system are shared by rent increase (allocation of refurbishment costs)

Experiences technical staff

Experience problems or failures?

n. a.

Find solutions to these problems or failures?

n. a.